

PRODUCT NAME:
HOLDING TANK

DESCRIPTION:
4000 THRU 6000 GALLONS
H-20 TRAFFIC RATED

DESIGN SPECIFICATIONS

DESIGN LOAD: H-20 TRAFFIC RATED

WITH DRY SOIL CONDITIONS (WATER LEVEL BELOW TANK). SUITABLE SUB-BASE BEDDED WITH GRANULAR MATERIAL SHALL BE PREPARED TO HANDLE ANTICIPATED LOADS. FOR COMPLETE DESIGN AND PRODUCT INFORMATION, PLEASE CONTACT PRO-CAST PRODUCTS.

PRO-CAST PRODUCTS RESERVES THE RIGHT TO MAKE CHANGES TO PRODUCT DESIGN AND/OR DIMENSIONS WITHOUT NOTICE. PLEASE CONTACT PRO-CAST PRODUCTS WHENEVER NECESSARY FOR CONFIRMATION OR ADVICE ON PRODUCT DESIGN.

NOTES:

1. NOT USED
2. REFER TO SPECIFICATION SHEET NOS. S-251 & S-252
3. REFER TO SPECIFICATION SHEET NO. S-201
4. REFER TO SPECIFICATION SHEET NO. S-250

SCALE: DO NOT SCALE
DRAWN BY: TPC 12.20.2024
REVISED BY:
CHECKED BY:

DRAWING NO.
H-005

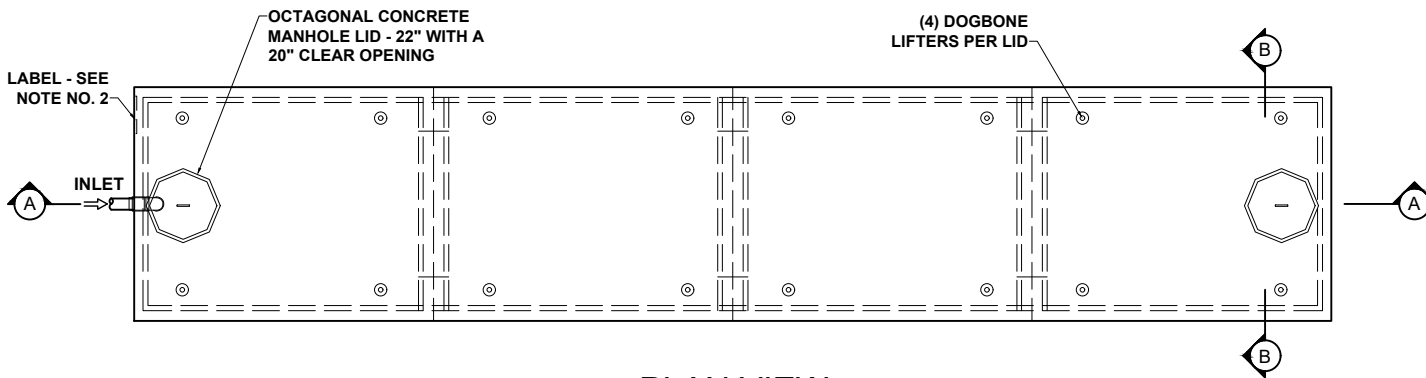

PLAN VIEW

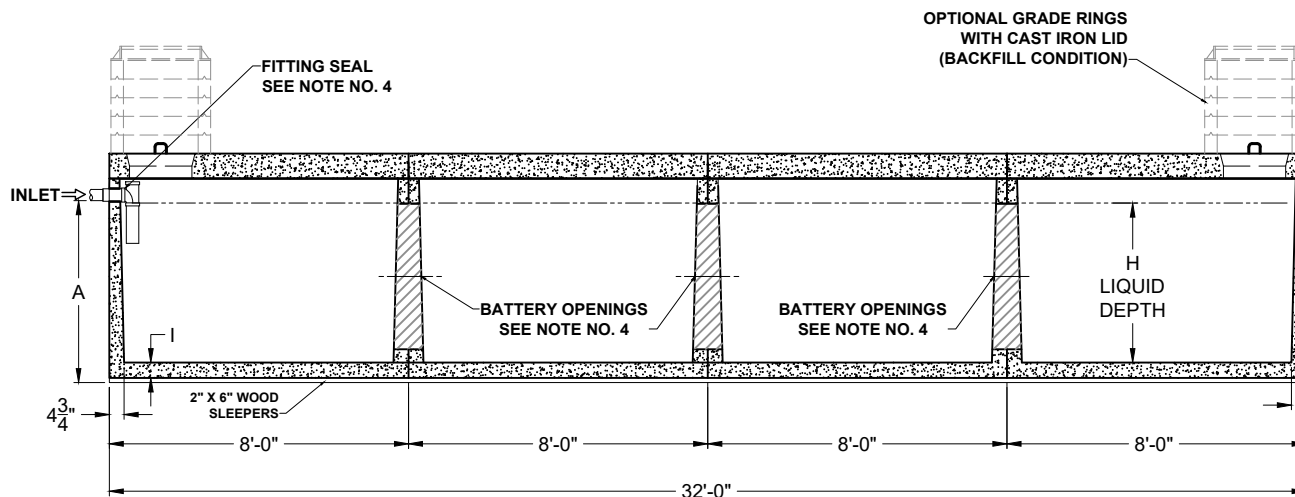

SECTION THRU "A-A"

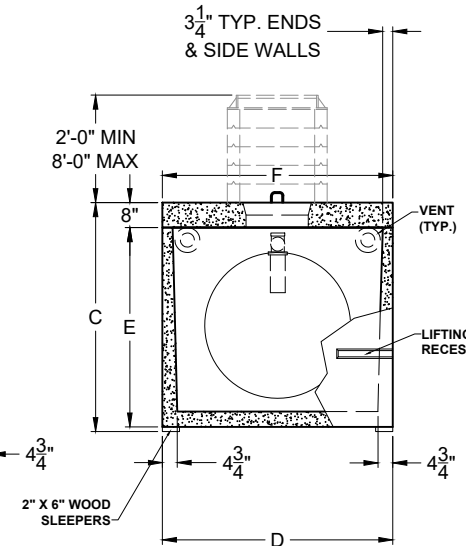

SECTION THRU "B-B"

H-20 TRAFFIC RATED
"HEAVY DUTY"

ALL DIMENSIONS ARE IN INCHES & WEIGHTS IN LBS - (RISER WT. NOT INCLUDED)										EXCAVATION SPECIFICATIONS				
MODEL	A	B	C	D	E	F	G	H	I	WEIGHT	LENGTH	WIDTH	BELOW INLET	TANK HEIGHT
PC S-4-4000-HD	50	N/A	65	74	55	74	24 3/4	41 1/2	4 1/2	50,640	35'-0"	9'-2"	4'-2"	5'-5"
PC S-4-5000-HD	59	N/A	74	74	64	74	29 3/4	50 1/2	4 1/2	55,500	35'-0"	9'-2"	4'-11"	6'-2"
PC S-4-6000-HD	62 1/2	N/A	77 1/2	85	67 1/2	85	30 3/4	53 1/2	5	64,880	35'-0"	10'-1"	5'-2 1/2"	6'-5 1/2"